



**NORDIN  
INDUSTRIES  
AUSTRALIA**



**SPAN GUIDE**

# **NORDIN PINE**

FORMWORK LVL - E14 F17 (95X63) E12 F14 (150X75)





# Table of Content

<b>Product</b>	<b>4</b>
<b>Structural Design</b>	<b>4</b>
<b>NordinPine LVL Joists (95X63 mm) Table</b>	<b>5</b>
<b>NordinPine LVL Bearers (150X75 mm) Table</b>	<b>6</b>
<b>Vertical Element Design Tables</b>	<b>7</b>

## Product

Nordin Pine LVL is structural Laminated Veneer Lumber (95X63 mm & 150X75 mm) that is used as a concrete formwork beams. Nordin Pine LVL is manufactured to meet the requirements of AS/NZS 4357 for structural LVL. Nordin Pine LVL is available in 1.8, 2.4, 3.6, 4.2, 4.8, and 6-meters lengths.

## Structural Design

The design tables have been prepared in accordance with the following design standards:

- AS 3610:1995 – Formwork for Concrete.
- AS 1720.1-2010 – Timber Structural Design.

The data presented includes allowances and limitations as per the standards.

*(Refer to the Span Table notes for detailed information).*

*Note: This is a guide only and a job-specific formwork design will be required for both Horizontal & Vertical elements.*



# NordinPine LVL (95X63 mm) Joists Table for Forming Soffits

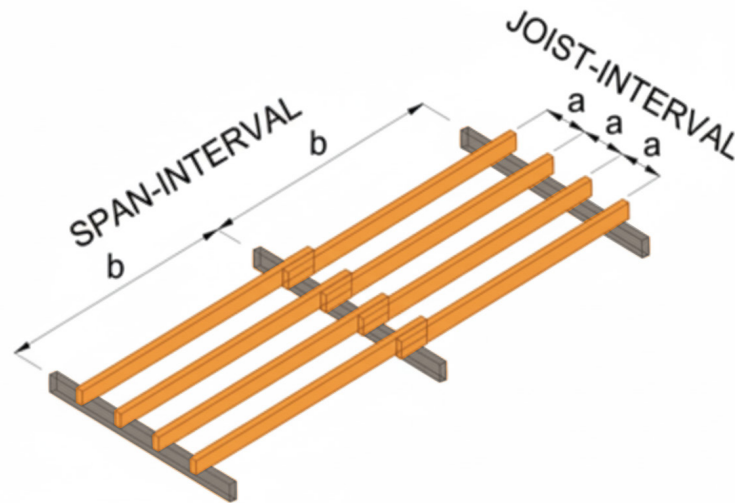

Concrete Slab Thickness (mm)	(a) Joist Spacing (mm)															
	200	225	300	350	400	450	480	600	200	225	300	350	400	450	480	600
	(b) Maximum Single Span (m)								(b) Maximum Multiple Span (m)							
100	2.2	2.2	2.0	1.9	1.8	1.7	1.7	1.5	2.6	2.5	2.4	2.3	2.2	2.1	2.1	2.0
150	2.1	2.1	1.9	1.8	1.7	1.6	1.6	1.5	2.5	2.4	2.3	2.2	2.1	2.1	2.1	2.0
200	2.0	2.0	1.8	1.7	1.6	1.6	1.6	1.4	2.4	2.4	2.2	2.2	2.0	2.0	2.0	1.9
250	1.9	1.9	1.7	1.6	1.5	1.5	1.4	1.3	2.4	2.4	2.2	2.1	2.0	2.0	2.0	1.8
300	1.9	1.8	1.7	1.6	1.5	1.5	1.5	1.4	2.3	2.3	2.1	2.0	2.0	1.9	1.9	1.8
400	1.8	1.7	1.6	1.5	1.4	1.3	1.3	1.2	2.3	2.2	2.1	2.0	1.9	1.9	1.8	1.8
500	1.7	1.6	1.5	1.4	1.3	1.3	1.2	1.2	2.2	2.1	2.0	1.9	1.9	1.9	1.8	1.7
600	1.6	1.6	1.4	1.3	1.2	1.2	1.2	1.1	2.1	2.1	1.9	1.9	1.8	1.7	1.7	1.6
700	1.5	1.5	1.4	1.3	1.2	1.2	1.2	1.1	2.0	1.9	1.9	1.8	1.7	1.7	1.7	1.5
800	1.5	1.5	1.3	1.2	1.2	1.1	1.1	1.0	2.0	1.9	1.9	1.8	1.7	1.7	1.7	1.5
900	1.5	1.4	1.3	1.2	1.2	1.1	1.1	1.0	2.0	1.9	1.8	1.8	1.7	1.6	1.6	1.5
1000	1.4	1.4	1.2	1.2	1.1	1.1	1.0	1.0	2.0	1.8	1.8	1.7	1.6	1.6	1.6	1.5

Table 1. Joist span table for forming slab soffits.

## General Notes for Standard Horizontal Forms Joists

- Design capacities are calculated for  $\Phi=0.90$  and for short duration load,  $K1 = 0.94$ – refer AS1720 & AS 3610.
- For bending capacity, laterally stable calculation i.2  $k12$  is as per AS 1720 Refer eq. 3.2(10)–(11)–(12).
- The average modulus of elasticity is 12878 Mpa. –Spruce Structure Laminated Veneer Lumber.
- Rigidity, bending, and shear capacities are given for orientation ‘on-edge’(bending about the x-axis) only.
- Properties apply for Nordin LVL that is dry and is in new or ‘as-new’ condition–reductions should be made for moisture content higher than 15% (see AS 1720) and for aged/used material.
- Design for the Joist table presented above includes a 4 Kpa allowance for stacking materials in accordance with AS 3610, Where the stacked material load is reduced in accordance with AS 3610, then spans used may be larger than those given above–refer formwork Design.
- In the above table, deflections limited to the greater of span [3mm, or  $L/270$ ] based on concrete Class 3 finish –refer to AS 3610. Finish quality is however also dependent upon be interpreted to necessarily guarantee the achievement of Class 3 finish.
- For multiple spans, the design has assumed:
  - The most conservative of two or three span use,
  - All spans equally loaded, and
  - All spans are equal.
- Span values may be interpolated for intermediate slab thicknesses.

# NordinPine LVL Bearers (150X75 mm) Table For Forming Soffits

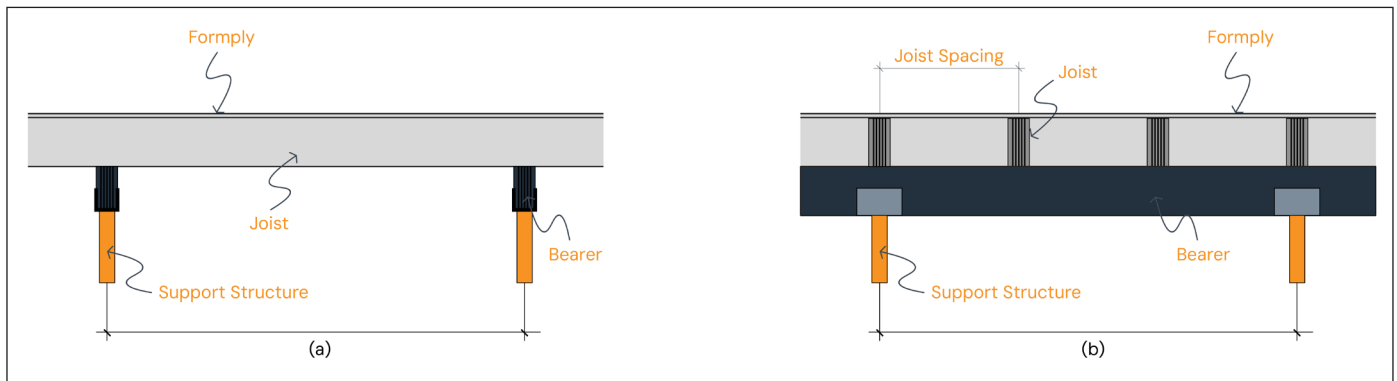

Concrete Slab Thickness (mm)	(a) Joist Spacing (mm)											
	900	1200	1500	1800	2100	2400	900	1200	1500	1800	2100	2400
	(b) Maximum Single Span (m)						(b) Maximum Multiple Span (m)					
100	2.2	2.0	1.8	1.7	1.6	1.6	2.7	2.6	2.5	2.4	2.2	2.1
150	2.1	1.9	1.8	1.7	1.6	1.5	2.6	2.5	2.4	2.2	2.1	2.0
200	2.0	1.8	1.7	1.6	1.5	1.5	2.5	2.3	2.2	2.1	2.0	2.0
250	1.9	1.8	1.7	1.6	1.5	1.5	2.4	2.3	2.2	2.1	2.0	2.0
300	1.9	1.7	1.6	1.5	1.4	1.4	2.3	2.2	2.1	2.0	1.8	1.9
400	1.8	1.6	1.5	1.4	1.3	1.3	2.2	2.1	2.0	1.8	1.6	1.4
500	1.7	1.5	1.4	1.3	1.3	1.3	2.2	2.0	1.8	1.6	1.4	1.3
600	1.6	1.5	1.4	1.3	1.2	1.2	2.1	2.0	1.6	1.2	1.2	1.1
700	1.5	1.4	1.3	1.2	1.2	1.2	2.0	1.9	1.5	1.2	1.1	1.0
800	1.5	1.4	1.3	1.2	1.1	1.1	2.0	1.7	1.4	1.1	1.0	0.9
900	1.4	1.3	1.2	1.1	1.0	1.0	1.9	1.4	1.2	1.0	0.9	0.8
1000	1.3	1.2	1.2	1.1	1.0	1.0	1.9	1.4	1.2	1.0	0.8	0.8

Table 2. Bearers span table for forming slab soffits.

## General Notes for Standard Horizontal Forms Joists

- Design capacities are calculated for  $\Phi=0.90$  and for short duration load,  $K1 = 0.94$ - refer AS1720 & AS 3610.
- For bending capacity, laterally stable calculation i.e  $k12$  is as per AS 1720 Refer eq. 3.2(10)-(11)-(12).
- The average modulus of elasticity is 12878 Mpa. -Spruce Structure Laminated Veneer Lumber.
- Rigidity, bending, and shear capacities are given for orientation 'on-edge'(bending about the x-axis) only.
- Properties apply for Nordin LVL that is dry and is in new or 'as-new' condition-reductions should be made for moisture content higher than 15% (see AS 1720) and for aged/used material.
- Design for the Joist table presented above includes a 4 Kpa allowance for stacking materials in accordance with AS 3610, Where the stacked material load is reduced in accordance with AS 3610, then spans used may be larger than those given above-refer formwork Design.
- In the above table, deflections limited to the greater of span [3mm, or  $L/270$ ] based on concrete Class 3 finish -refer to AS 3610. Finish quality is however also dependent upon be interpreted to necessarily guarantee the achievement of Class 3 finish.
- For multiple spans, the design has assumed:
  - The most conservative of two or three span use,
  - All spans equally loaded, and
  - All spans are equal.
- Span values may be interpolated for intermediate slab thicknesses.

# Vertical Element Design Tables Using Nordin Pine LVL (95X63 mm)

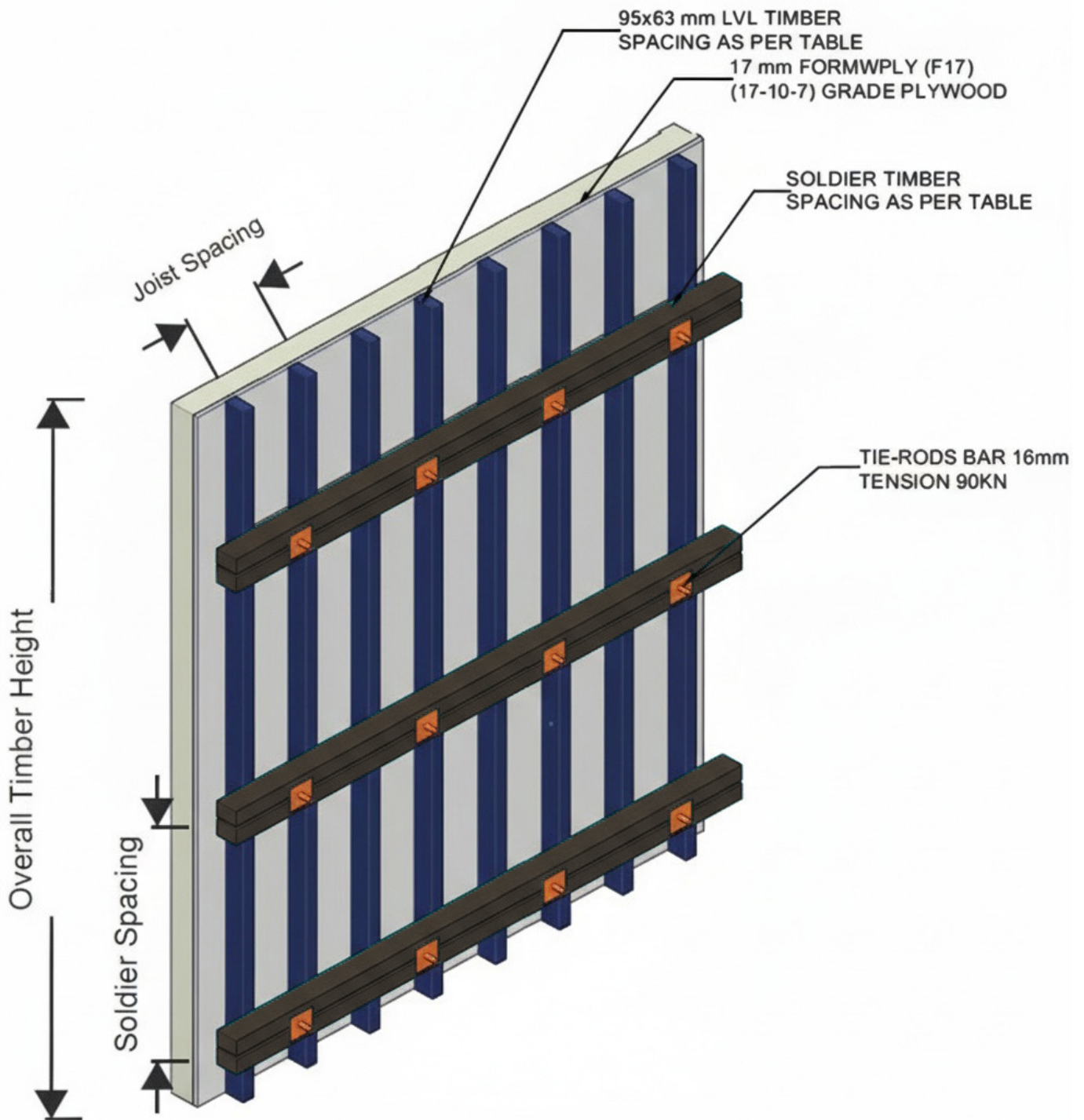

## General Notes for Standard Vertical Forms

- Specifications intended for achievement of Class 3 Finish.
- Designs based upon hydrostatic pressure distribution.
- Formface specifications assume plywood continuous over 3 or more spans except where noted otherwise.
- Holes for tie bolts must not be bored through soldier or timber joists.
- Tie Rod spacing and Tie-Rod Material used depends on the Soldier material (Timber, Bearers, steel Whalers, etc.). The Tie Rod spacing will need to be confirmed by a Structural Engineer/ Formwork Designer depending on the material that is intended to be used.

## Height upto 1.8 m

Timber Length 1.8 m			
Soldier Spacing (mm)	Fresh Concrete Pressure [KN/m <sup>2</sup> ]	Joist LVL 95 X 63 mm Spacing (mm)	Deflection (mm)
a = 300	25	450	<0.9
b = 900	30	450	<0.9
c = 600	45	360	<0.9

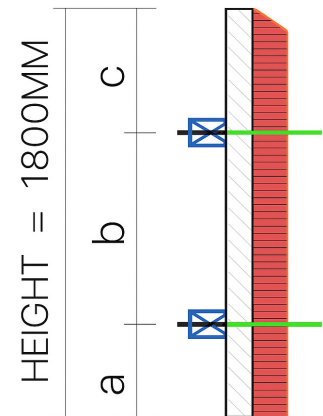

## Height upto 3.0 m

Timber Length 3.0 m			
Soldier Spacing (mm)	Fresh Concrete Pressure [KN/m <sup>2</sup> ]	Joist LVL 95 X 63 mm Spacing (mm)	Deflection (mm)
a = 300	25	350	<0.9
b = 1000	30	350	<0.9
d = 1100	54	360	1.1
c = 600	72	300	1.1

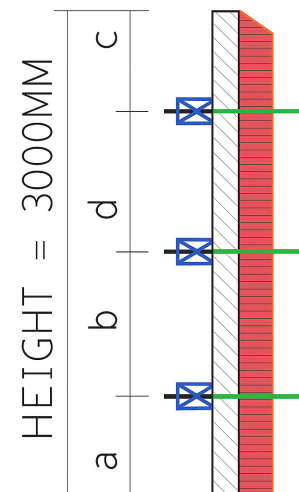

## Height upto 3.6 m

Timber Length 3.6 m			
Soldier Spacing (mm)	Fresh Concrete Pressure [KN/m <sup>2</sup> ]	Joist LVL 95 X 63 mm Spacing (mm)	Deflection (mm)
a = 200	30	400	<0.9
b = 700	40	360	<0.9
d = 1000	54	360	1.2
e = 1100	67	360	1.1
c = 600	90	300	<0.9

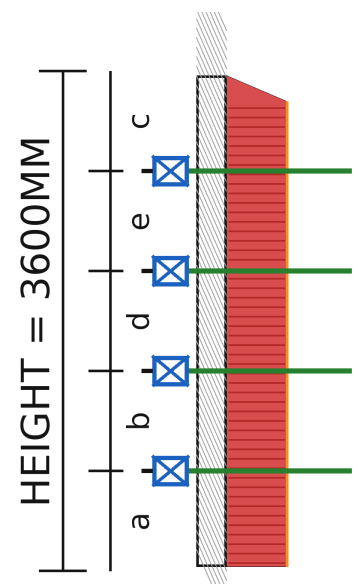

## Height upto 4.8 m

Timber Length 4.8 m			
Soldier Spacing (mm)	Fresh Concrete Pressure [KN/m <sup>2</sup> ]	Joist LVL 95 X 63 mm Spacing (mm)	Deflection (mm)
a = 200	30	450	<0.9
b = 800	40	450	<0.9
d = 800	50	450	<0.9
e = 800	60	400	<0.9
f = 900	70	400	<0.9
j = 900	80	360	<0.9
c = 400	90	360	1

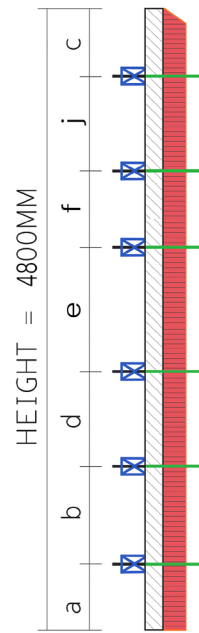

## Height upto 6.0 m

Timber Length 6.0 m			
Soldier Spacing (mm)	Fresh Concrete Pressure [KN/m <sup>2</sup> ]	Joist LVL 95 X 63 mm Spacing (mm)	Deflection (mm)
a = 200	30	360	<0.9
b = 800	40	360	<0.9
d = 800	50	360	<0.9
e = 800	60	360	1.1
f = 1000	70	360	1.3
j = 1000	80	300	1.1
h = 1000	90	300	1.1
c = 400	100	300	1.1

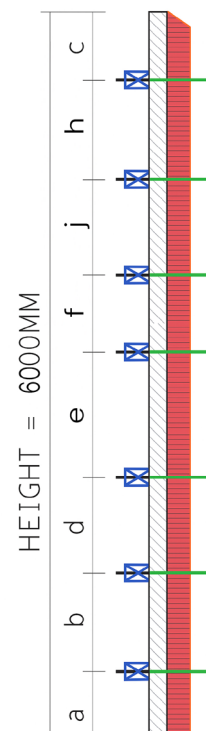



**NORDIN  
INDUSTRIES  
AUSTRALIA**

27 Atkinson Road,  
Taren Point NSW 2229

Tel (Office) : 02 95884422

Website : [www.nordins.com.au](http://www.nordins.com.au)

Email : [info@nordins.com.au](mailto:info@nordins.com.au)

